

Drawing 1 - Fixture Mounting

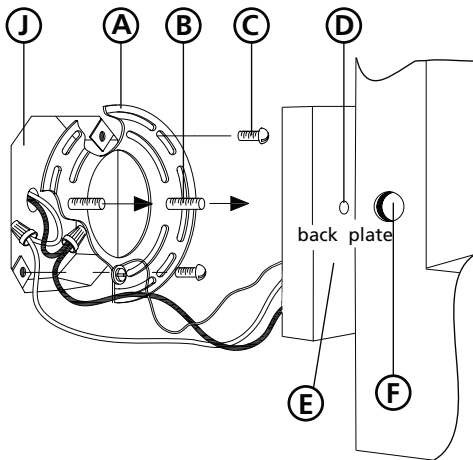

1

1. Find a clear area in which you can work.
2. Unpack fixture and glass from carton.
3. Carefully review instructions prior to assembly.

***** The construction of this fixture will be accomplished by first mounting the retaining plate to the junction box, making all necessary electrical connections, mounting the fixture to the wall and then lamping fixture.**

2

1. Prepare mounting strap (A) by threading the two 1 1/4" long mounting screws (B) into the back of the mounting strap (A) - see **Drawing 1**.

- Be sure the holes into which the screws are threaded match the spacing of holes (D) in the backplate (E).

2. Attach mounting strap (A) to junction box (J) using two 1" screws (C) provided.

Drawing 2 - Relamping

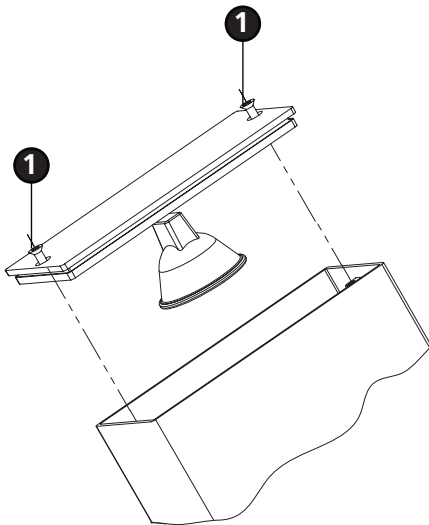

3

3. Make electrical connections from supply wire to fixture lead wires. Refer to instruction sheet (I.S. 18) and follow all instructions to make all necessary wiring connections. Then refer back to this sheet to continue installation of this fixture.

4

1. To mount fixture, slip the two mounting screws (B) through the two mounting holes (D) in the backplate (E) - see **Drawing 1**.
2. While holding fixture in place, thread the two ball knobs (F) on to the end of the mounting screws (B), and tighten.

5

1. To lamp fixture, remove the 2 phillip head screws (1) at the top and bottom of the fixture to gain access - see **Drawing 1**.
2. Fixture can now be lamped accordingly.
3. To reassemble, follow step 1 in reverse order.